

*38th International Electric Vehicle Symposium and Exhibition
(EVS38) Göteborg, Sweden, June 15-18, 2025*

Final Paper guidelines

Author1¹, Author2²

¹*Author1 (corresponding author) affiliation, address, email*

²*State affiliation of other authors if different*

Executive Summary

Insert summary text here in 10.5pt Times New Roman font. The text of the outline is justified with 1½ line spacing. The outline should contain between 50 and 150 words. The outline shall be enclosed within two horizontal lines 1pt thick.

Keywords: please enter, in italic, five keywords from the [provided list](#). The keywords on the paper shall match those selected when submitting

1 Header

This is the template for the EVS38 symposium final paper. Your final paper should not exceed 12 pages.

The body of the text is Times New Roman 10.5pt, justified with single line spacing.

Sections are numbered sequentially. Headings are 14pt bold (automatically set in L^AT_EX); headings for Nomenclature, Acknowledgements, References and Authors are not numbered.

1.1 Subsections

Sub-headings should be numbered as above. Subsections are numbered sequentially. Headings are 12pt bold (automatically set in L^AT_EX).

1.1.1 Sub-subsections

Sub-subheading, if any, are also numbered as above. Sub-subsections are numbered sequentially. Headings are 10.5pt bold (automatically set in L^AT_EX).

1.2 Header/Title section

This denotes how to format the header of your abstract. The title of the conference shall be set in "Large". The Paper title shall be set in "LARGE". Author names in "large"; affiliations (one affiliation per line, stating institution, address and email) in "small" and italic ("em").

2 File requirements

The abstract shall be uploaded as a pdf file only, made up to the specifications of this template. In the case special fonts (e.g. symbols) are used, these shall be embedded in the pdf file. The size of the file should not exceed 10MB with a total allowed length of a maximum of 12 pages.

3 Page and Column Dimensions

The printed page area is set as follows:

- top and bottom margins 30 mm (1.18 inches)
- left and right margin 25 mm (0.98 inches)

A footer is to be provided, with a horizontal line 1 pt thick at 20 mm from the bottom of the page. Below the line, left align the statement "EVS38 International Electric Vehicle Symposium" and right align the page number, all set in "small".

4 Referencing

Referencing sources in the abstract and final paper shall be done with sequential numerical references, between square brackets. Examples of citing references are given in the references section, for books [1], journal articles[2] and websites[3]. The reference list is printed in "small".

If a bibliography reference file is used (BibTeX), please make use of the attached evs.bst file.

5 Figures, Tables and Equations

5.1 Figures

Captions for figures are "small", centered. Do not include separate lists of table and figure captions. Figures shall be sequentially numbered, lined up with the text, and referenced as Fig.1.

Vector graphics files (.eps, .svg, .ai) are preferred for line drawings; bitmap figures like photos (.jpg) shall have sufficient resolution (300 ppi).

The use of colour figures is welcomed, but the choice of colours should allow a suitable contrast when reproduced on a monochrome printer.

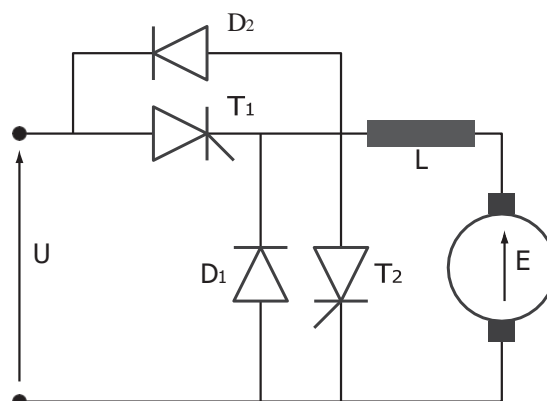

Figure 1: Chopper for d.c. drive

5.2 Tables

Tables shall have their own sequential numbering independent from the figures numbering, and captions shall be placed above the table.

Table 1: Power levels for charging (230 V)

	Current (A)	Power (kW)
Standard	16	3,5
Semi-fast	32	7,0

5.3 Equations

Equations shall be set within the text and numbered sequentially with the number enclosed in round brackets.

$$E = \int_0^t U \cdot I \cdot \cos \phi \cdot dt \quad (1)$$

Acknowledgments

List acknowledgments here if appropriate.

For bibliography, please use the attached bst file or format as follows:

References

- [1] J.J. Romm. *The hype about Hydrogen*, ISBN 1-55963-704-8, Washington, Island Press, 2005.
- [2] P. Van den Bossche et.al., *SUBAT, an assessment of sustainable battery technology*, Journal of Power sources, ISSN 0378-7753, 162(2006), 913-919.
- [3] *EVS30*, <http://www.evs30.org>, accessed on 2020-11-06.
- [4] Van Mierlo J, Berecibar M, El Baghdadi M, De Cauwer C, Messagie M, Coosemans T, Jacobs VA, Hegazy O. *Beyond the State of the Art of Electric Vehicles: A Fact-Based Paper of the Current and Prospective Electric Vehicle Technologies*. World Electric Vehicle Journal. 2021; 12(1):20. <https://doi.org/10.3390/wevj12010020>

Presenter Biography



Authors shall provide a short biography. Biographies should have a typical length of 5 to 10 lines, in "small", be limited to main educational background and description of current activities, and preferably be accompanied by a photograph sized 20 by 30 mm. The photograph shall be lined up with the bottom of the text paragraph.